

Intellimod™ Module Dual-In-Line Intelligent Power Module 5 Amperes/1200 Volts

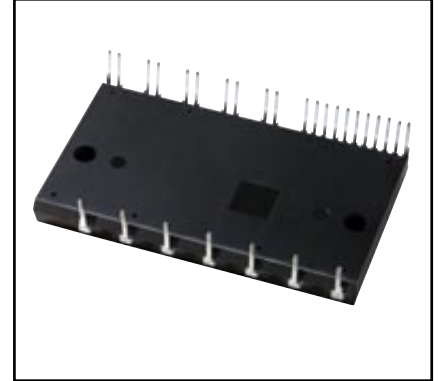
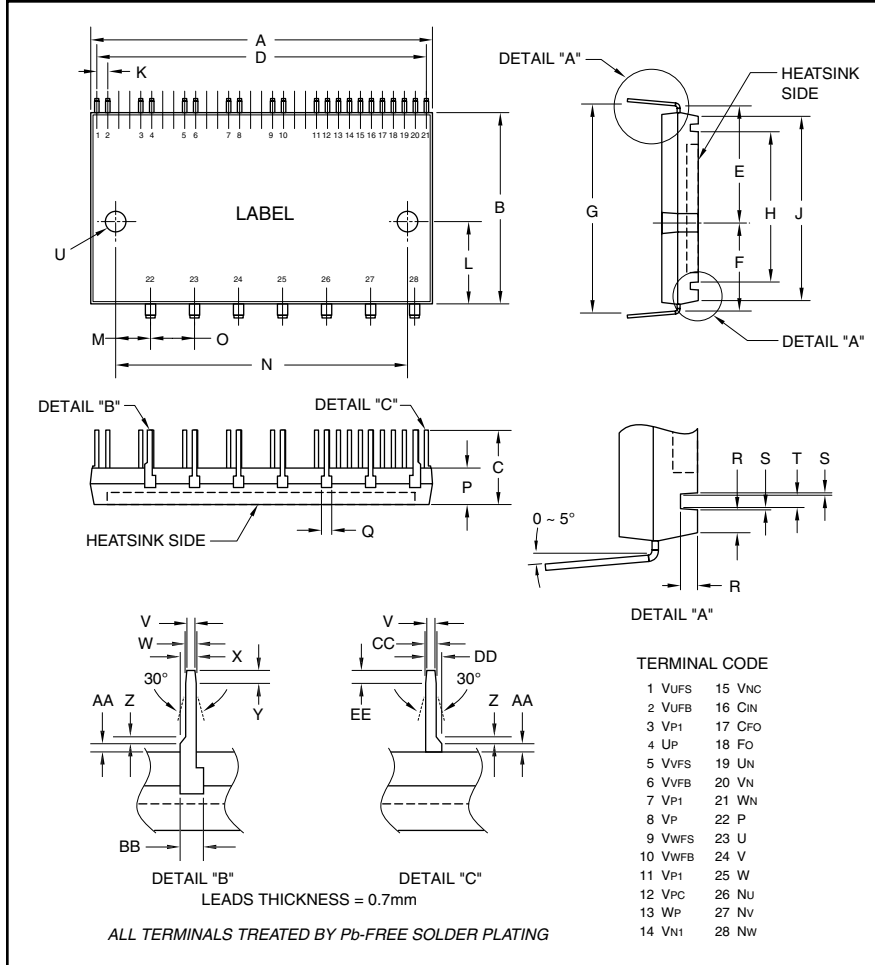

Description:

DIP-IPMs are intelligent power modules that integrate power devices, drivers, and protection circuitry in an ultra compact dual-in-line transfer-mold package for use in driving small three phase motors. Use of 4th generation IGBTs, DIP packaging, and application specific HVICs allow the designer to reduce inverter size and overall design time.

Features:

- Compact Packages
- Single Power Supply
- Integrated HVICs
- Direct Connection to CPU

Applications:

- Washing Machines
- Refrigerators
- Air Conditioners
- Small Servo Motors
- Small Motor Control

Ordering Information:

PS22052 is a 1200V, 5 Ampere DIP Intelligent Power Module.

Outline Drawing and Circuit Diagram

Dimensions	Inches	Millimeters
A	3.11±0.02	79.0±0.5
B	1.73±0.02	44.0±0.5
C	0.63±0.01	16.1±0.3
D	3.0	76.2
E	1.08±0.02	27.4±0.5
F	0.80±0.02	20.4±0.5
G	1.91±0.02	48.6±0.5
H	1.34±0.02	34.0±0.5
J	1.67±0.02	42.5±0.5
K	0.10±0.01	2.54±0.3
L	0.73±0.02	18.5±0.5
M	0.31±0.01	8.0±0.3
N	2.64±0.01	67.0±0.3
O	0.40±0.01	10.16±0.3
P	0.32±0.02	8.2±0.5

Dimensions	Inches	Millimeters
Q	0.09	2.5
R	0.08	2.0
S	0.01	0.3
T	0.07	1.7
U	0.18±0.008 Dia.	4.5±0.2 Dia.
V	0.024	0.6
W	0.039±0.008	1.0±0.2
X	0.06±0.008	1.5±0.2
Y	0.05	1.2
Z	0.02	0.5
AA	0.024±0.02	0.6±0.5
BB	0.098	2.5
CC	0.031±0.008	0.8±0.2
DD	0.051±0.008	1.3±0.2
EE	0.04	1.0

PS22052
Intellimod™ Module
Dual-In-Line Intelligent Power Module
 5 Amperes/1200 Volts

Absolute Maximum Ratings, $T_j = 25^\circ\text{C}$ unless otherwise specified

Characteristics	Symbol	PS22052	Units
Power Device Junction Temperature*	T_j	-20 to 125	$^\circ\text{C}$
Module Case Operation Temperature (See Note 1)	T_C	-20 to 100	$^\circ\text{C}$
Storage Temperature	T_{stg}	-40 to 125	$^\circ\text{C}$
Mounting Torque, M4 Mounting Screws	—	13	in-lb
Module Weight (Typical)	—	77	Grams
Self-protection Supply Voltage Limit (Short Circuit Protection Capability)**	$V_{CC(prot.)}$	800	Volts
Heatsink Flatness (See Note 2)	—	-50 to 100	μm
Isolation Voltage, AC 1 minute, 60Hz Sinusoidal, Connection Pins to Heatsink Plate	V_{ISO}	2500	Volts

*The maximum junction temperature rating of the power chips integrated within the DIP-IPM is 150°C ($@ T_C \leq 100^\circ\text{C}$). However, to ensure safe operation of the DIP-IPM, the average junction temperature should be limited to $T_{j(av)} \leq 125^\circ\text{C}$ ($@ T_C \leq 100^\circ\text{C}$).

** $V_D = 13.5 \sim 16.5\text{V}$, Inverter Part, $T_j = 125^\circ\text{C}$, Non-repetitive, Less than $2\mu\text{s}$

IGBT Inverter Sector

Collector-Emitter Voltage	V_{CES}	1200	Volts
Collector Current ($T_C = 25^\circ\text{C}$)	$\pm I_C$	5	Amperes
Peak Collector Current ($T_C = 25^\circ\text{C}$, $<1\text{ms}$)	$\pm I_{CP}$	10	Amperes
Supply Voltage (Applied between P-NU, NV, NW)	V_{CC}	900	Volts
Supply Voltage, Surge (Applied between P-NU, NV, NW)	$V_{CC(surge)}$	1000	Volts
Collector Dissipation ($T_C = 25^\circ\text{C}$, per 1 Chip)	P_C	38.3	Watts

Control Sector

Supply Voltage (Applied between $V_{P1}-V_{PC}$, $V_{N1}-V_{NC}$)	V_D	20	Volts
Supply Voltage (Applied between $V_{UFB}-V_{UFS}$, $V_{VFB}-V_{VFS}$, $V_{WFB}-V_{WFS}$)	V_{DB}	20	Volts
Input Voltage (Applied between U_P, V_P, W_P-V_{PC} , U_N, V_N, W_N-V_{NC})	V_{IN}	$-0.5 \sim V_D+0.5$	Volts
Fault Output Supply Voltage (Applied between F_O-V_{NC})	V_{FO}	$-0.5 \sim V_D+0.5$	Volts
Fault Output Current (Sink Current at F_O Terminal)	I_{FO}	1	mA
Current Sensing Input Voltage (Applied between $C_{IN}-V_{NC}$)	V_{SC}	$-0.5 \sim V_D+0.5$	Volts

Note 1 – T_C Measure Point

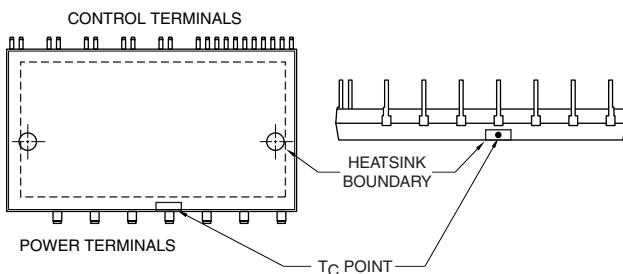

Note 2 – Flatness Measurement Position

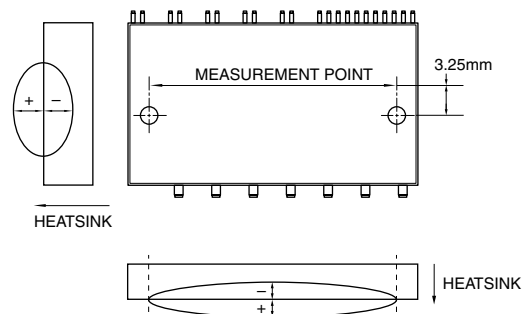



Powerex, Inc., 200 E. Hillis Street, Youngwood, Pennsylvania 15697-1800 (724) 925-7272

PS22052
Intellimod™ Module
Dual-In-Line Intelligent Power Module
5 Amperes/1200 Volts

Electrical and Mechanical Characteristics, $T_j = 25^\circ\text{C}$ unless otherwise specified

Characteristics	Symbol	Test Conditions	Min.	Typ.	Max.	Units
IGBT Inverter Sector						
Collector-Emitter Saturation Voltage	$V_{CE(sat)}$	$I_C = 5\text{A}, T_j = 25^\circ\text{C}, V_D = V_{DB} = 15\text{V}, V_{IN} = 5\text{V}$	—	2.7	3.4	Volts
		$I_C = 5\text{A}, T_j = 125^\circ\text{C}, V_D = V_{DB} = 15\text{V}, V_{IN} = 5\text{V}$	—	2.5	3.2	Volts
Diode Forward Voltage	V_{EC}	$-I_C = 5\text{A}, V_{IN} = 0\text{V}$	—	2.4	2.9	Volts
Inductive Load Switching Times	t_{on}		0.8	1.5	2.2	μs
	t_{rr}	$V_{CC} = 600\text{V}, V_D = V_{DB} = 15\text{V},$	—	0.2	—	μs
	$t_{C(on)}$	$I_C = 5\text{A}, T_j = 125^\circ\text{C}, V_{IN} = 0 \Leftrightarrow 5\text{V},$	—	0.4	0.7	μs
	t_{off}	Inductive Load (Upper-Lower Arm)	—	2.8	3.8	μs
	$t_{C(off)}$		—	0.4	0.7	μs
Collector-Emitter Cutoff Current	I_{CES}	$V_{CE} = V_{CES}, T_j = 25^\circ\text{C}$	—	—	1.0	mA
		$V_{CE} = V_{CES}, T_j = 125^\circ\text{C}$	—	—	10	mA

Control Sector

Circuit Current $V_D = V_{DB} = 15\text{V}$	I_D	$V_{IN} = 5\text{V}$	Total of $V_{P1}-V_{PC}, V_{N1}-V_{NC}$	—	—	3.70	mA
			$V_{UFB}-V_{UFS}, V_{VFB}-V_{VFS}, V_{WFB}-V_{WFS}$	—	—	1.30	mA
		$V_{IN} = 0\text{V}$	Total of $V_{P1}-V_{PC}, V_{N1}-V_{NC}$	—	—	3.50	mA
			$V_{UFB}-V_{UFS}, V_{VFB}-V_{VFS}, V_{WFB}-V_{WFS}$	—	—	1.30	mA
Fault Output Voltage	V_{FOH}	$V_{SC} = 0\text{V}, F_O$ Terminal Pull-up to 5V by 10k Ω	4.9	—	—	Volts	
	V_{FOL}	$V_{SC} = 1\text{V}, I_{FO} = 1\text{mA}$	—	—	1.10	Volts	
Input Current	I_{IN}	$V_{IN} = 5\text{V}$	0.70	1.5	2.00	mA	
Short Circuit Trip Level*	$V_{SC(ref)}$	$V_D = 15\text{V}$	0.43	0.48	0.53	Volts	
Supply Circuit Under-voltage	UV_{DBt}	Trip Level, $T_j \leq 125^\circ\text{C}$	10.0	—	12.0	Volts	
	UV_{DBr}	Reset Level, $T_j \leq 125^\circ\text{C}$	10.5	—	12.5	Volts	
	UV_{Dt}	Trip Level, $T_j \leq 125^\circ\text{C}$	10.3	—	12.5	Volts	
	UV_{Dr}	Reset Level, $T_j \leq 125^\circ\text{C}$	10.8	—	13.0	Volts	
Fault Output Pulse Width**	t_{FO}	$C_{FO} = 22\text{nF}$	1.6	2.4	—	ms	
ON Threshold Voltage	$V_{th(on)}$	Applied between $U_P, V_P, W_P-V_{PC},$	2.5	3.0	4.2	Volts	
OFF Threshold Voltage	$V_{th(off)}$	U_N, V_N, W_N-V_{NC}	0.8	1.4	2.0	Volts	

* Short Circuit protection is functioning only for N-side IGBTs. Please select the value of the external shunt resistance such that the SC trip level is less than 1.7 times the current rating.
 **Fault output is asserted when the lower arms short circuit or control supply under-voltage protection function operates. The fault output pulse-width t_{FO} depends on the capacitance value of C_{FO} according to the following approximate equation: $C_{FO} = (9.3 \times 10^{-6}) \times t_{FO} \text{ (F)}$.



Powerex, Inc., 200 E. Hillis Street, Youngwood, Pennsylvania 15697-1800 (724) 925-7272

PS22052
Intellimod™ Module
Dual-In-Line Intelligent Power Module
 5 Amperes/1200 Volts

Thermal Characteristics

Characteristic	Symbol	Condition	Min.	Typ.	Max.	Units
Junction to Case	$R_{th(j-c)Q}$	IGBT Part (Per 1/6 Module)	—	—	2.61	°C/Watt
Thermal Resistance	$R_{th(j-c)D}$	FWDi Part (Per 1/6 Module)	—	—	3.81	°C/Watt
Contact Thermal resistance	$R_{th(c-f)}$	Per 1 Module	—	—	0.047	°C/Watt

Recommended Conditions for Use

Characteristic	Symbol	Condition	Min.	Typ.	Value	Units
Supply Voltage	V_{CC}	Applied between P-NU, NV, NW	350	600	800	Volts
Control Supply Voltage	V_D	Applied between V_{P1} - V_{PC} , V_{N1} - V_{NC}	13.5	15.0	16.5	Volts
	V_{DB}	Applied between V_{UFB} - V_{UFS} , V_{VFB} - V_{VFS} , V_{WFB} - V_{WFS}	13.5	15.0	16.5	Volts
Control Supply Variation	dV_D , dV_{DB}	—	-1	—	1	V/ μ s
Arm Shoot-through Blocking Time	t_{DEAD}	For Each Input Signal, $T_C \leq 100^\circ\text{C}$	3.3	—	—	μ s
PWM Input Frequency	f_{PWM}	$T_j \leq 125^\circ\text{C}$, $T_C \leq 100^\circ\text{C}$	—	—	15	kHz
Output r.m.s. Current*	I_O	$V_{CC} = 600\text{V}$, $V_D = V_{DB} = 15\text{V}$, $f_C = 5\text{kHz}$ P.F. = 0.8, Sinusoidal PWM, $T_j \leq 125^\circ\text{C}$, $T_f \leq 100^\circ\text{C}$	—	—	5.5	A_{rms}
		$V_{CC} = 600\text{V}$, $V_D = V_{DB} = 15\text{V}$, $f_C = 15\text{kHz}$ P.F. = 0.8, Sinusoidal PWM, $T_j \leq 125^\circ\text{C}$, $T_f \leq 100^\circ\text{C}$	—	—	3.2	A_{rms}
		—	—	—	—	—
Allowable Minimum Input	$P_{WIN(on)}$ **	—	1.5	—	—	μ s
Pulse Width	$P_{WIN(off)}$ ***	$I_C \leq 5\text{A}$	2.6	—	—	μ s
		$5 < I_C \leq 8.5\text{A}$	2.8	—	—	μ s
N Line Wiring Inductance Less than 10nH						
V_{NC} Voltage Variation	V_{NC}	Between V_{NC} -NU, NV, NW (Including Surge)	-5.0	—	5.0	Volts

*The allowable r.m.s. current also depends on the user application conditions.

**DIP-IPM might make no response to the input ON signal with pulse width less than $P_{WIN(on)}$.

***DIP-IPM might make no response or not work properly if the input OFF signal pulse width is less than $P_{WIN(off)}$.

PS22052
Intellimod™ Module
Dual-In-Line Intelligent Power Module
 5 Amperes/1200 Volts

Application Circuit

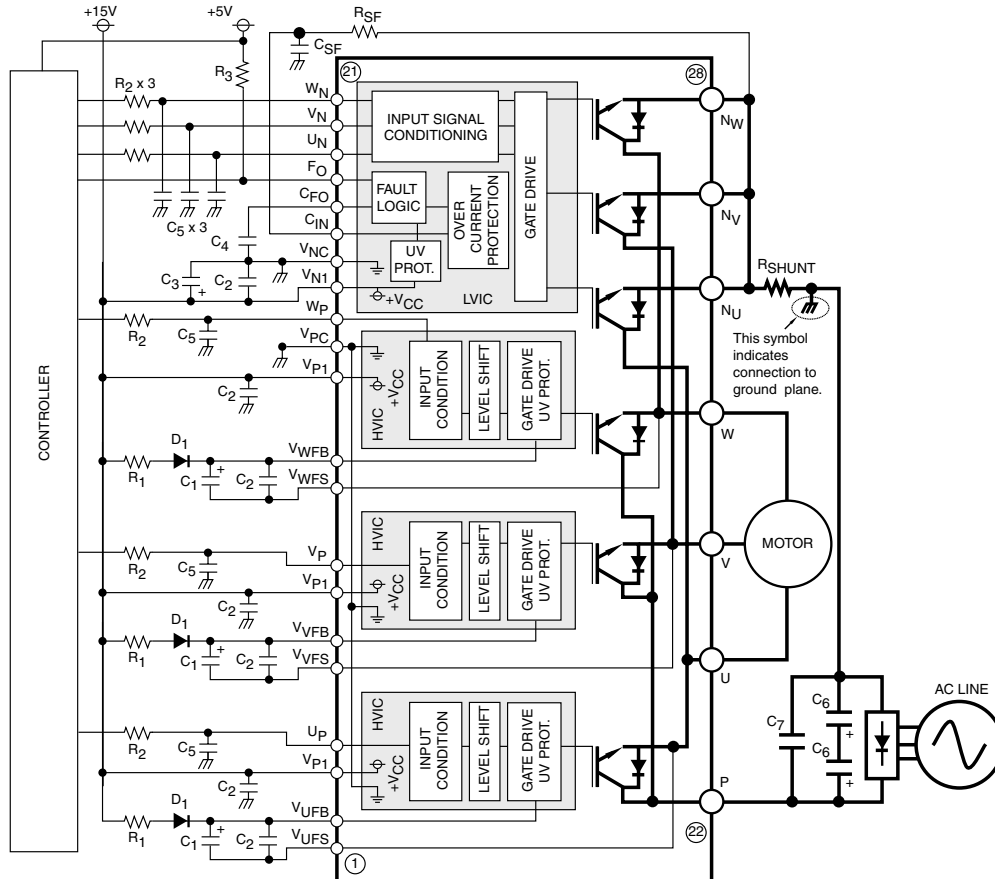

Component Selection:

Dsgn.	Typ. Value	Description
D ₁	1A, 1200V	Boot strap supply diode – Ultra fast recovery
C ₁	10-100uF, 50V	Boot strap supply reservoir – Electrolytic, long life, low impedance, 105°C (Note 5)
C ₂	0.22-2.0uF, 50V	Local decoupling/High frequency noise filters – Multilayer ceramic (Note 8)
C ₃	10-100uF, 50V	Control power supply filter – Electrolytic, long life, low impedance, 105°C
C ₄	22nF, 50V	Fault lock-out timing capacitor – Multilayer ceramic (Note 4)
C ₅	100pF, 50V	Optional input signal noise filter – Multilayer ceramic (Note 1)
C ₆	200-2000uF, 450V	Main DC bus filter capacitor – Electrolytic, long life, high ripple current, 105°C
C ₇	0.1-0.22uF, 1000V	Surge voltage suppression capacitor – Polyester/polypropylene film (Note 9)
C _{SF}	1000pF, 50V	Short circuit detection filter capacitor – Multilayer ceramic (Note 6, Note 7)
R _{SF}	1.8k ohm	Short circuit detection filter resistor (Note 6, Note 7)
R _{SHUNT}	5-100 mohm	Current sensing resistor – Non-inductive, temperature stable, tight tolerance (Note 10)
R ₁	10 ohm	Boot strap supply inrush limiting resistor (Note 5)
R ₂	330 ohm	Optional control input noise filter (Note 1, Note 2)
R ₃	10k ohm	Fault output signal pull-up resistor (Note 3)

Notes:

- To prevent input signal oscillations minimize wiring length to controller (~2cm). Additional RC filtering (C5 etc.) may be required. If filtering is added be careful to maintain proper dead time and voltage levels. See application notes for details.
- Internal HVIC provides high voltage level shifting allowing direct connection of all six driving signals to the controller.
- F_O output is an open collector type. Pull up resistor (R3) should be adjusted to current sink capability of the modules pins.
- C4 sets the fault output duration and lock-out time. $C4 = 9.3E^{-6} \times t_{FO}$. 22nF gives ~2.4ms.
- Boot strap supply component values must be adjusted depending on the PWM frequency and technique.
- Wiring length associated with R_{SHUNT}, R_{SF}, C_{SF} must be minimized to avoid improper operation of the OC function.
- R_{SF}, C_{SF} set over circuit protection trip time. Recommend time constant is 1.5us-2.0us. See application notes.
- Local decoupling/high frequency filter capacitors must be connected as close as possible to the modules pins.
- The length of the DC link wiring between C6, C7, the DIP's P terminal and the shunt must be minimized to prevent excessive transient voltages. In particular, C7 should be mounted as close to the DIP as possible.
- Use a high quality, tight tolerance current sensing resistor. Connect resistor as close as possible to the DIP's N terminal. Be careful to check for proper power rating. See application notes for calculation of resistance value.

PS22052
 Intellimod™ Module
 Dual-In-Line Intelligent Power Module
 5 Amperes/1200 Volts

Protection Function Timing Diagrams

Short-Circuit Protection (N-side only, with external shunt resistor and CR filter)

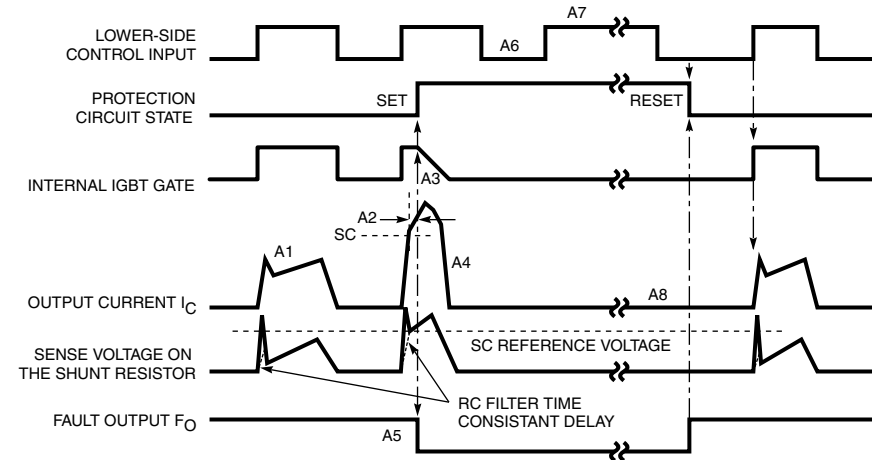

- A1: Normal operation – IGBT turn on and conducting current.
- A2: Short-circuit current detected (SC trigger).
- A3: IGBT gate hard interrupted.
- A4: IGBT turn off.
- A5: F_O output with a fixed pulse width (determined by the external capacitance C_{FO}).
- A6: Input "L" – IGBT off.
- A7: Input "H" – IGBT on is blocked during the F_O output period.
- A8: IGBT stays in off state.

Under-Voltage Protection (N-side, UV_D)

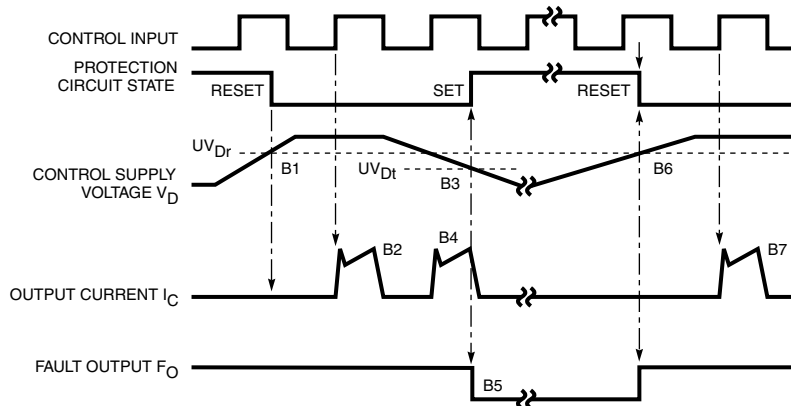

- B1: Control supply voltage rise – After the voltage level reaches UV_{Dr} , the drive circuit begins to work at the rising edge of the next input signal.
- B2: Normal operation – IGBT turn on and conducting current.
- B3: Under-voltage trip (UV_{Dt}).
- B4: IGBT turn off regardless of the control input level.
- B5: F_O asserted during the period from minimum pulse width or until control supply recover to UV_{Dr} .
- B6: Under-voltage reset (UV_{Dr}).
- B7: Normal operation – IGBT turn on and conducting current.

PS22052
Intellimod™ Module
Dual-In-Line Intelligent Power Module
 5 Amperes/1200 Volts

Protection Function Timing Diagrams

Under-Voltage Protection (P-side, UV_{DB})

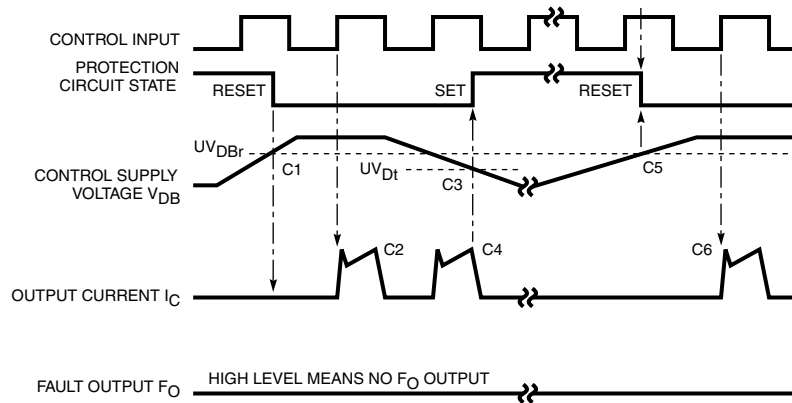

- C1: Control supply voltage rises – After the voltage level reaches UV_{DBr} , the drive circuit begins to work at the rising edge of the next input signal.
- C2: Normal operation – IGBT turn on and conducting current.
- C3: Under-voltage trip (UV_{DBt}).
- C4: IGBT stays off regardless of the control input level, but there is no F_O signal output.
- C5: Under-voltage reset (UV_{Dr}).
- C6: Normal operation – IGBT turn on and conducting current.

Typical Interface Circuit

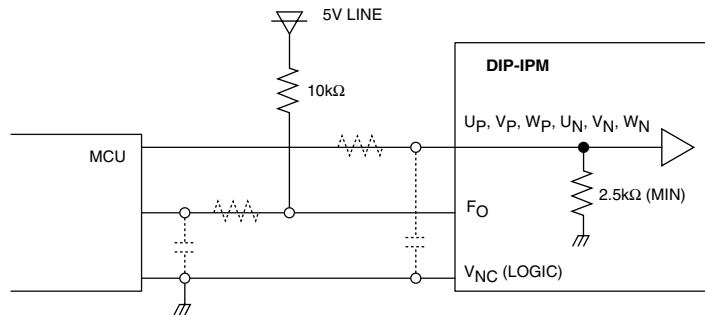

NOTE: RC coupling at each input (parts shown dotted) may change depending on the PWM control scheme used in the application and the wiring impedance of the printed circuit board. The DIP-IPM input signal section integrates a 2.5kΩ (min) pull-down resistor. Therefore, when using an external filtering resistor, care must be taken to satisfy the turn-on threshold voltage requirement.

Wiring Method Around Shunt Resistor

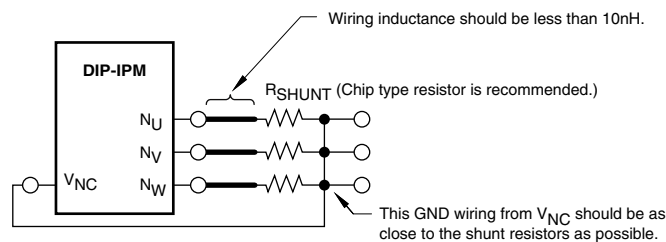

PS22052
Intellimod™ Module
Dual-In-Line Intelligent Power Module
 5 Amperes/1200 Volts

OUTPUT CHARACTERISTICS
(TYPICAL - INVERTER PART)

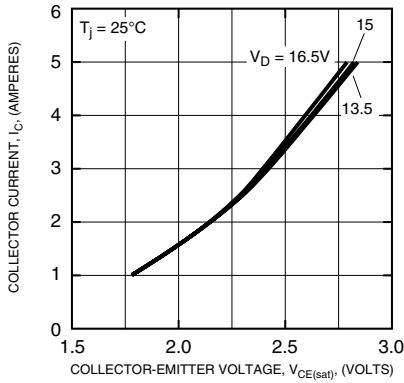

COLLECTOR-EMITTER SATURATION VOLTAGE CHARACTERISTICS
(TYPICAL - INVERTER PART)

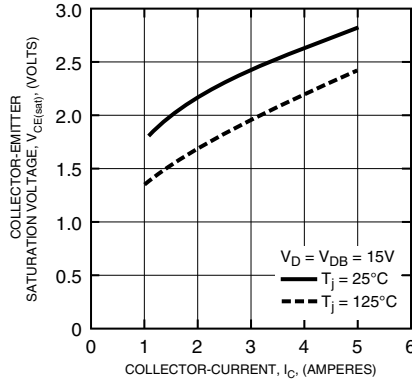

COLLECTOR-EMITTER SATURATION VOLTAGE VS. SUPPLY VOLTAGE CHARACTERISTICS
(TYPICAL - INVERTER PART)

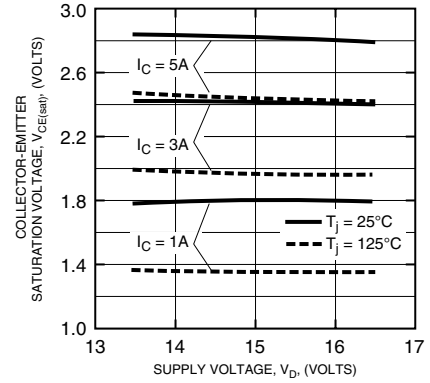

FREE-WHEEL DIODE FORWARD CHARACTERISTICS
(TYPICAL - INVERTER PART)

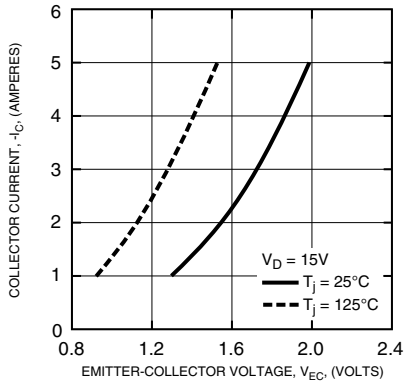

REVERSE RECOVERY CHARACTERISTICS
(TYPICAL - INVERTER PART N-SIDE)

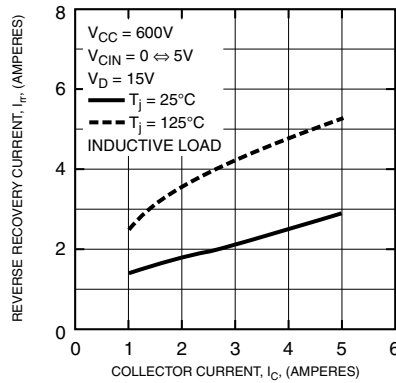

REVERSE RECOVERY CHARACTERISTICS
(TYPICAL - INVERTER PART N-SIDE)

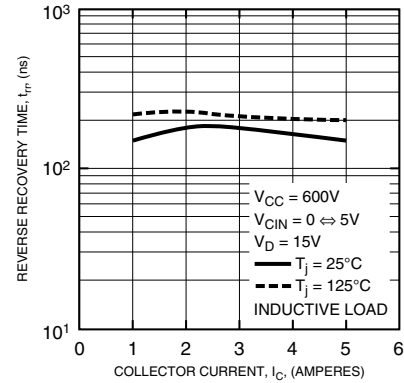

REVERSE RECOVERY CHARACTERISTICS
(TYPICAL - INVERTER PART P-SIDE)

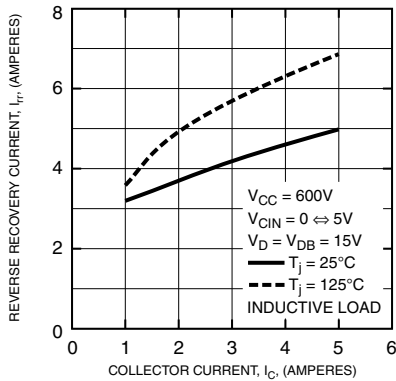

REVERSE RECOVERY CHARACTERISTICS
(TYPICAL - INVERTER PART P-SIDE)

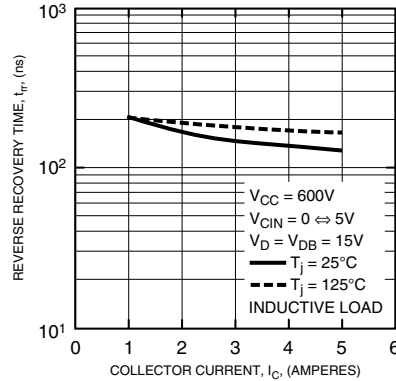

SWITCHING LOSS (ON) VS. COLLECTOR CURRENT
(TYPICAL - INVERTER PART N-SIDE)

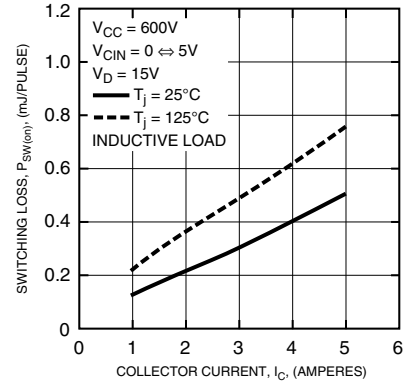

PS22052
Intellimod™ Module
Dual-In-Line Intelligent Power Module
 5 Amperes/1200 Volts

SWITCHING LOSS (OFF) VS. COLLECTOR CURRENT (TYPICAL - INVERTER PART N-SIDE)

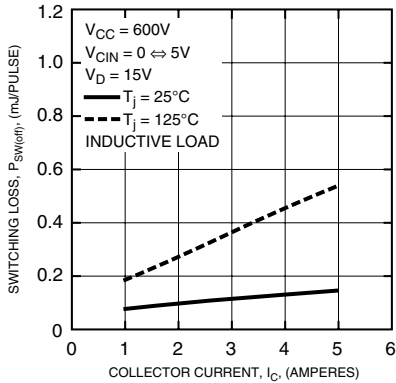

SWITCHING LOSS (ON) VS. COLLECTOR CURRENT (TYPICAL - INVERTER PART P-SIDE)

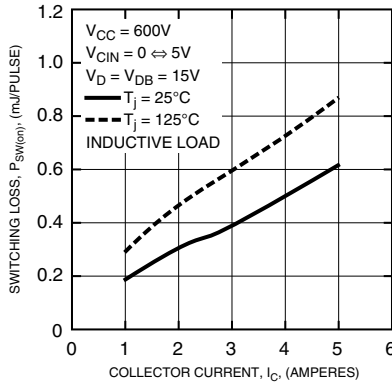

SWITCHING LOSS (OFF) VS. COLLECTOR CURRENT (TYPICAL - INVERTER PART P-SIDE)

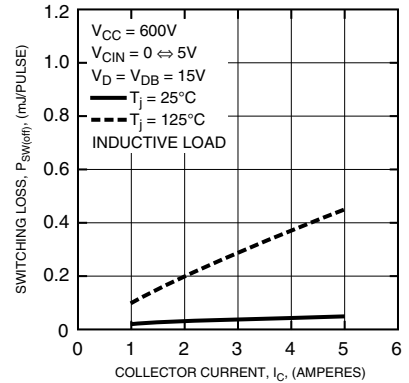

SWITCHING TIME (ON) VS. COLLECTOR CURRENT (TYPICAL - INVERTER PART N-SIDE)

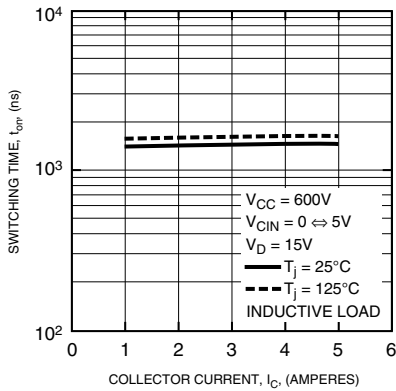

SWITCHING TIME (OFF) VS. COLLECTOR CURRENT (TYPICAL - INVERTER PART N-SIDE)

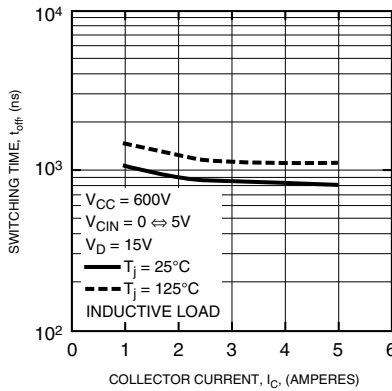

SWITCHING TIME (ON) VS. COLLECTOR CURRENT (TYPICAL - INVERTER PART P-SIDE)

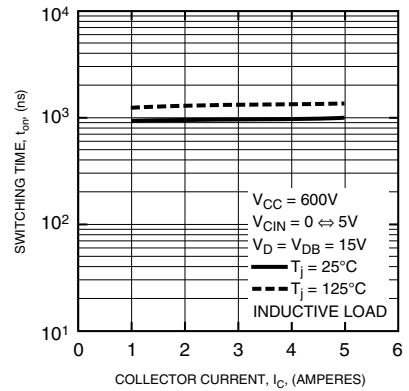

SWITCHING TIME (OFF) VS. COLLECTOR CURRENT (TYPICAL - INVERTER PART P-SIDE)

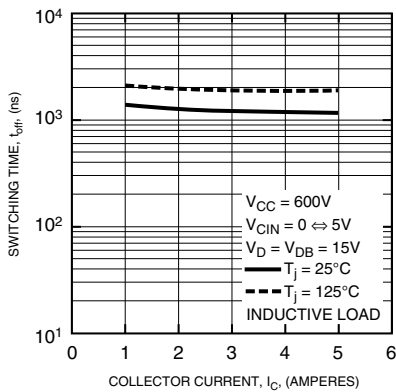

SWITCHING TIME (ON) VS. COLLECTOR CURRENT (TYPICAL - INVERTER PART N-SIDE)

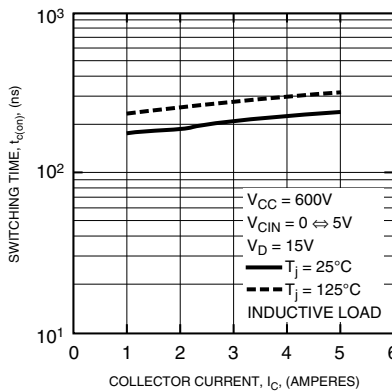

SWITCHING TIME (OFF) VS. COLLECTOR CURRENT (TYPICAL - INVERTER PART N-SIDE)

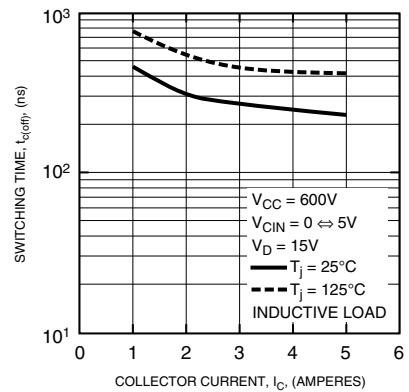

PS22052
Intellimod™ Module
Dual-In-Line Intelligent Power Module
5 Amperes/1200 Volts

SWITCHING TIME (ON) VS. COLLECTOR CURRENT (TYPICAL - INVERTER PART P-SIDE)

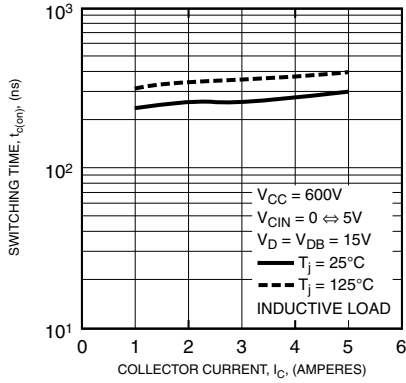

SWITCHING TIME (OFF) VS. COLLECTOR CURRENT (TYPICAL - INVERTER PART P-SIDE)

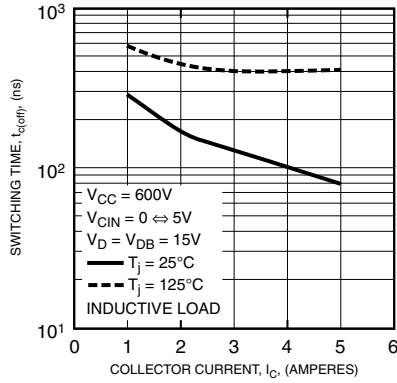

THRESHOLD VOLTAGE VS. JUNCTION TEMPERATURE CHARACTERISTICS (TYPICAL - CONTROL PART N-SIDE)

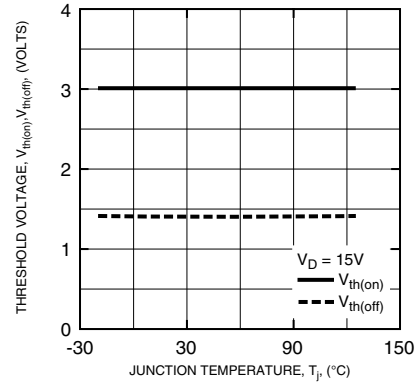

THRESHOLD VOLTAGE VS. JUNCTION TEMPERATURE (TYPICAL - CONTROL PART P-SIDE)

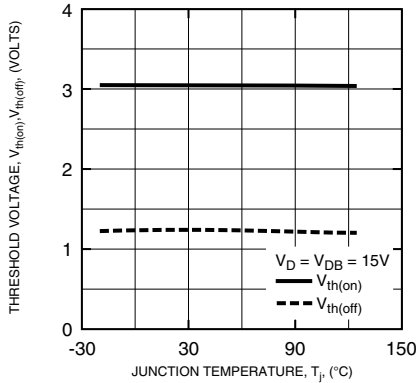

TRIP LEVEL CONTROL SUPPLY UNDER-VOLTAGE VS. JUNCTION TEMPERATURE (TYPICAL - CONTROL PART N-SIDE)

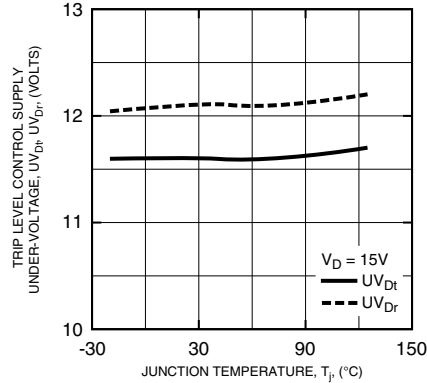

TRIP LEVEL CONTROL SUPPLY UNDER-VOLTAGE VS. JUNCTION TEMPERATURE (TYPICAL - CONTROL PART P-SIDE)

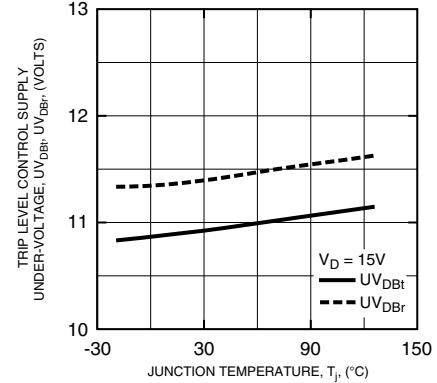

SHORT CIRCUIT TRIP LEVEL VOLTAGE VS. JUNCTION TEMPERATURE (TYPICAL - CONTROL PART N-SIDE)

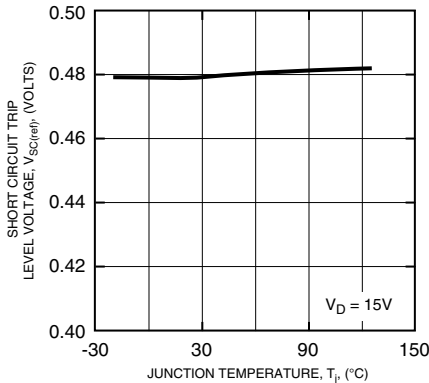

CIRCUIT CURRENT VS. DUTY CHARACTERISTICS (TYPICAL - CONTROL PART)

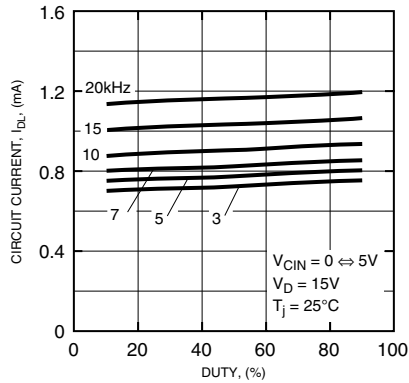

CIRCUIT CURRENT VS. DUTY CHARACTERISTICS (TYPICAL - CONTROL PART)

